

QMATEC 3030TS

FOUNDATION RIG WITH EXTENDABLE UNDERCARRIAGE



qmatec

MACHINE

Engine Model	Deutz TCD 6.1 Stage V
Engine Power	180 kW
Tractive Power	33 000 Nm
Track Width	500 mm
Weight std. from	33 000 kg

MAST

Feed Stroke	7 000 mm
Feed Force	14 000 kg
Retract Force	30 000 kg
Mast Winch	1500 / 4000 kg
Drill Table	Ø750 / Ø850 mm
Mast Displacement	1500 mm
Rapid Feed	0,30 m/sec
Rapid Pull up	0,30 m/sec
Pipe Wrench Cylinder	Ø 90 mm
Mast Rotation	+/- 45 deg.

ROTATION HEAD

Torque	7 000 / 45 000 Nm
Rotation Speed	0-63 / 0-18 rpm
Spindle Threads	API 5-1/2" IF

OTHER

Oscillation on Tracks	+/- 45 deg.
Track Speed	2,5 / 4,0 km/h
Battery	2 x 75 Ah
Hydr. Tank	430 L
Diesel Tank	360 L

SELECTION OF OPTIONAL EQUIPMENT

Main Winch 6700 kg.
 Break-Out Clamps
 Welding Machine/Generator and Water Pumps
 Water Tanks / Tool Cabinets
 Crane 2.7 tm or 4 tm, Radio Operated
 Digital Inclinometer w/Display on Radio
 Lubrication System
 Side-Parking for Rotation Head
 Other Equipment Delivered acc. to Agreement

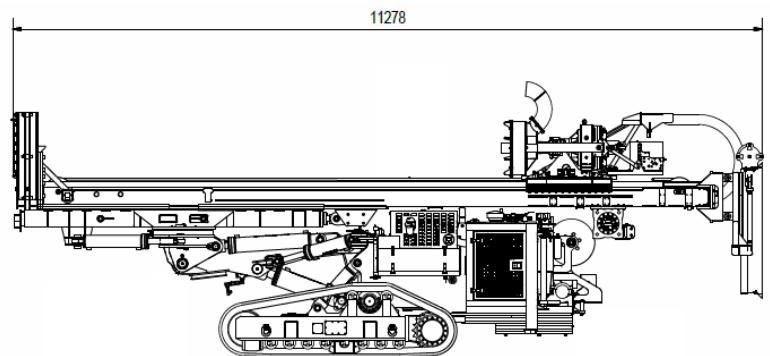
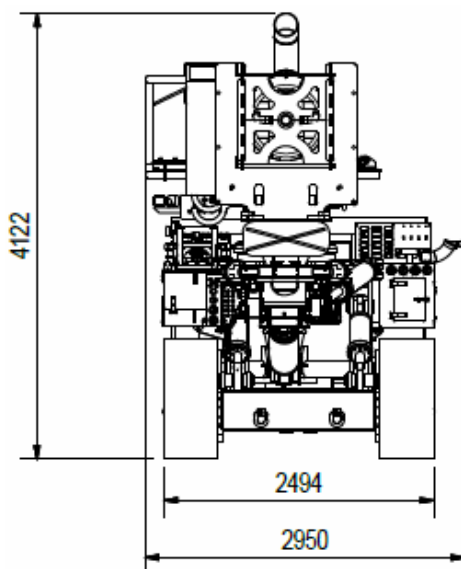

qmatec.com

mail@qmatec.com

+47 35 06 34 00